

Contents at a Glance – Mill 2D

Tips and Techniques 1

Setting the Environment 3

Lesson 1 - CAD only 13



Exercise 1a page 24

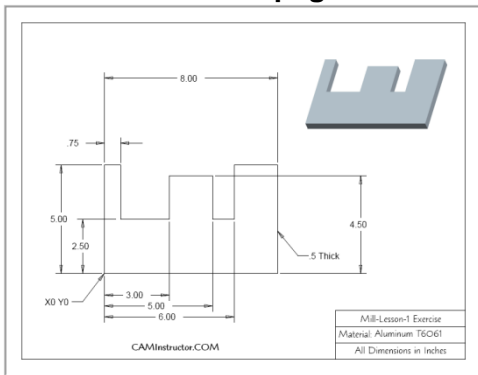

Exercise 1b page 25

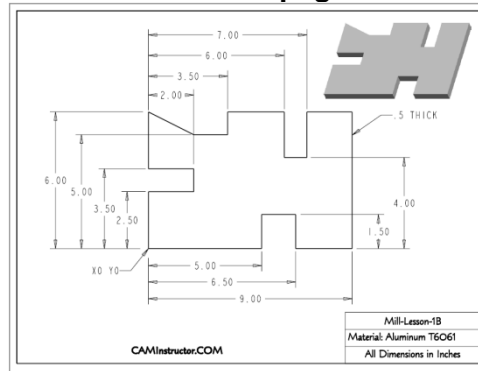

Lesson 2 - CAD only 27



Exercise 2a page 52

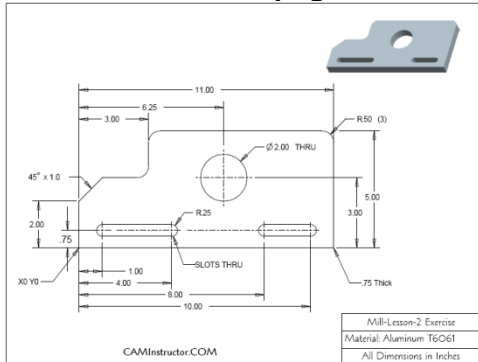

Exercise 2b page 53

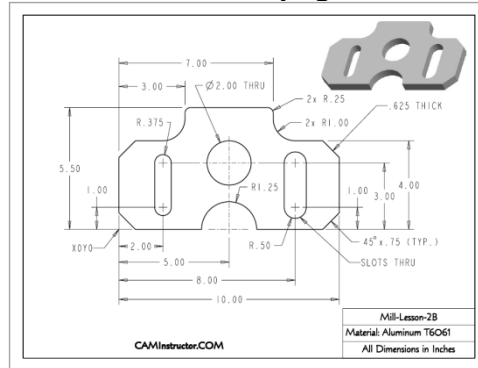

Lesson 3 – CAD/CAM 55

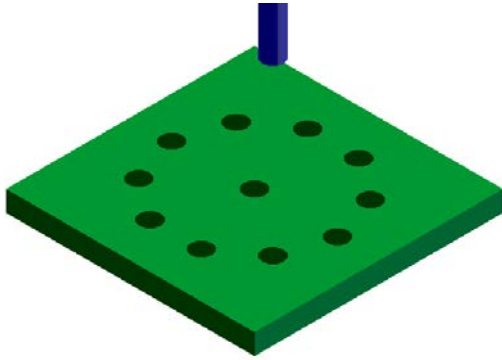

Exercise 3a page 98

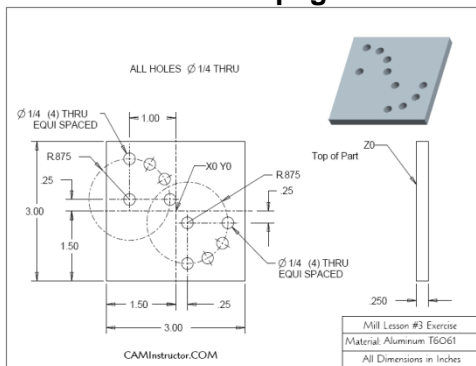

Exercise 3b page 99

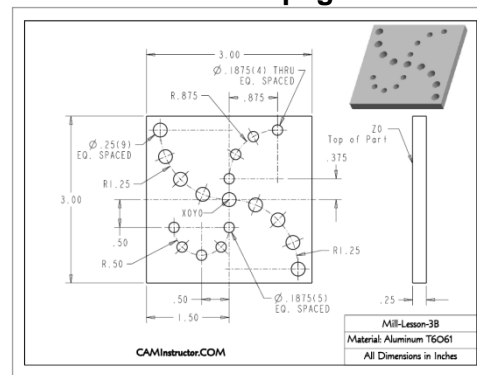

Lesson 4 – CAD/CAM 101

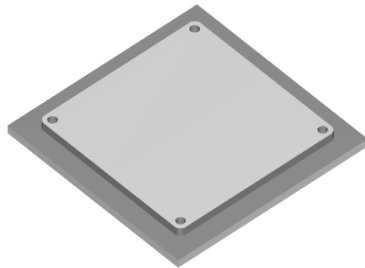

Exercise 4a page 138

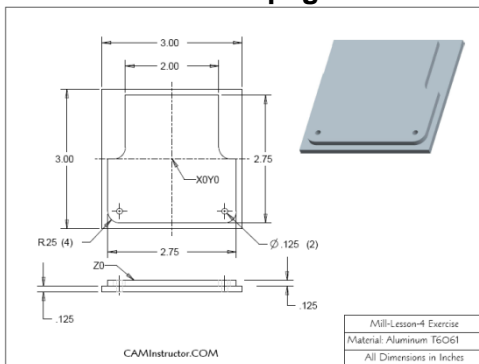

Exercise 4b page 139

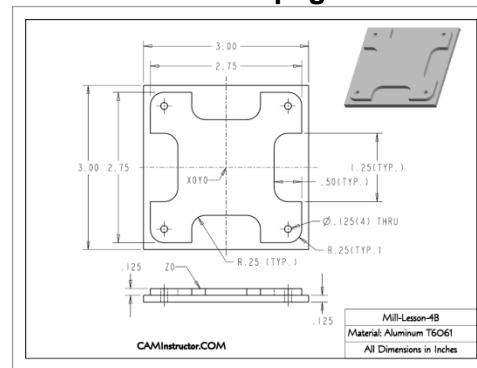

Lesson 5 – CAD/CAM 141

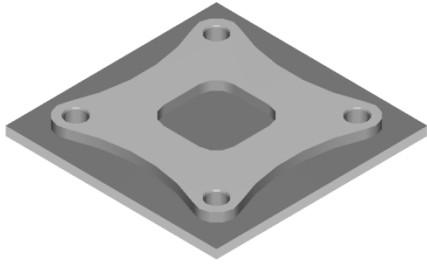

Exercise 5a page 205

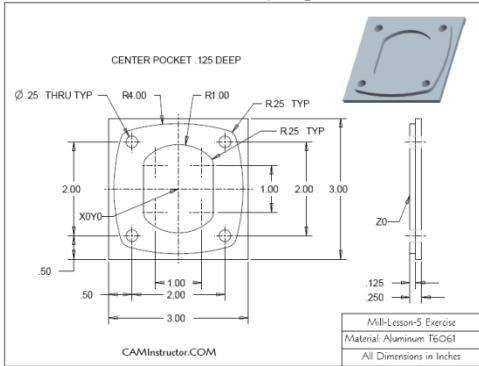

Exercise 5b page 206

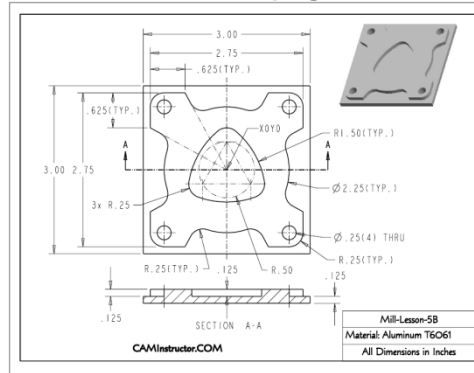

Lesson 6 - CAD 207

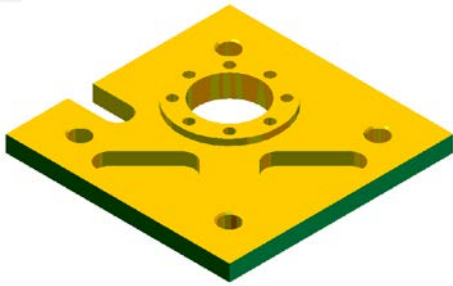

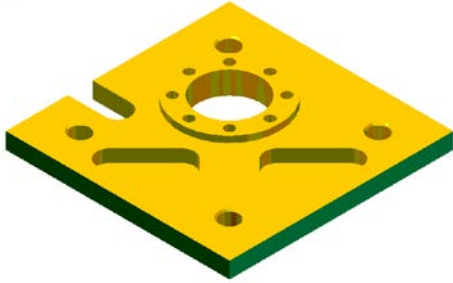

Exercise 7a page 312

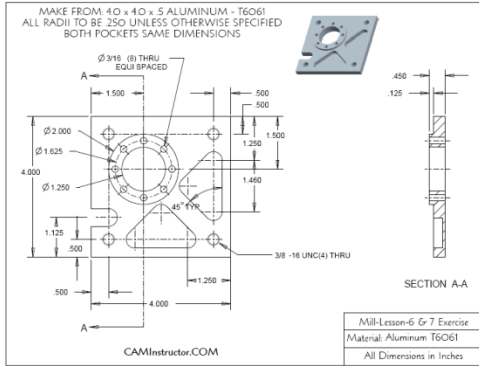

Exercise 7b page 313

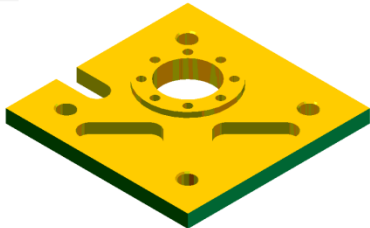
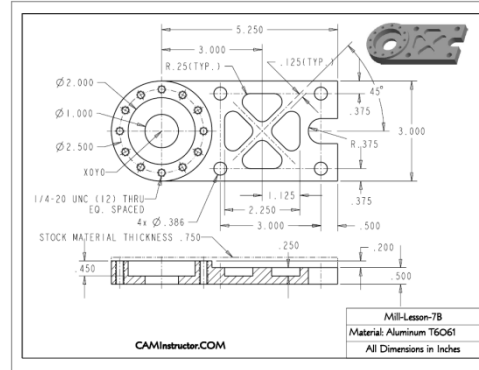

Feature Based Machining Lessons

Feature Based Machining Lesson 1 - CAM..... 513

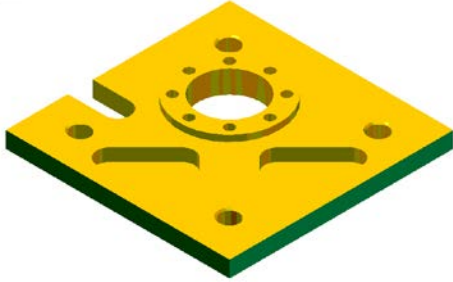

Feature Based Machining Lesson 2 - CAM..... 515

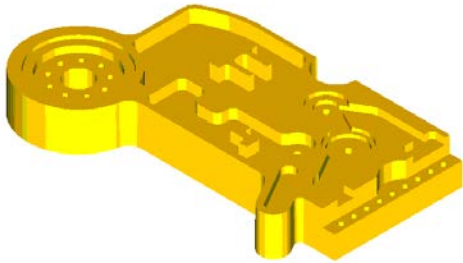

Work Coordinate System Lessons

WCS-Part-1 517

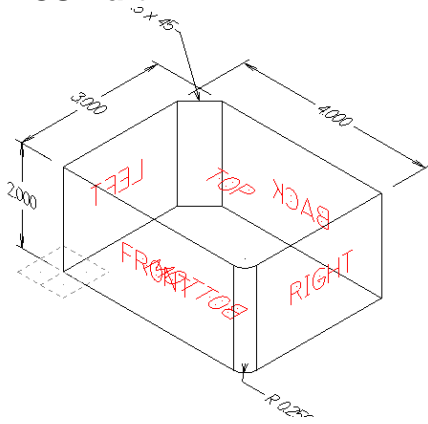

WCS-Part-2 519

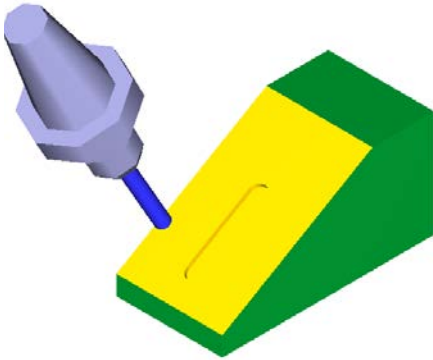

WCS-Part-3 521

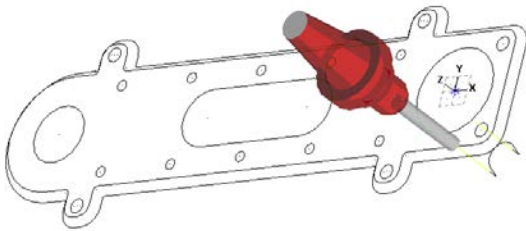

WCS-Part-4 523

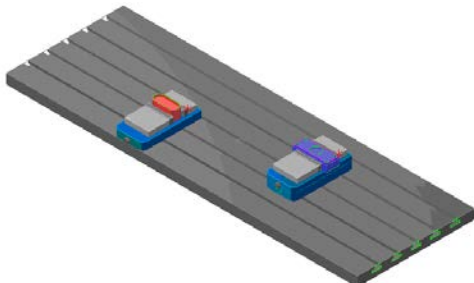

Advanced Exercises

Advanced Exercise 1 525



Advanced Exercise 2 529

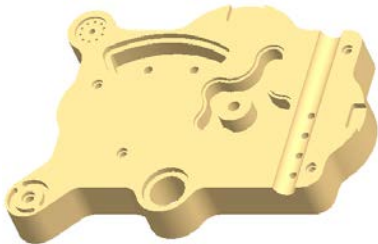

Advanced Exercise 3 533



Provided by CamInstructor Inc.
www.caminstructor.com
sales@caminstructor.com
1-877-873-6867

All rights reserved
