

Contents at a Glance – Mill 2D

Setting the Environment 1

Tips and Techniques 11

Lesson 1 13



Exercise 1a page 24

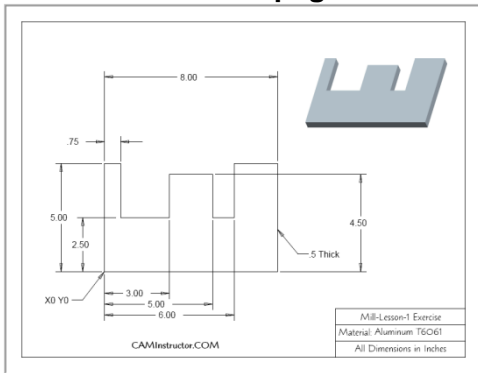

Exercise 1b page 25

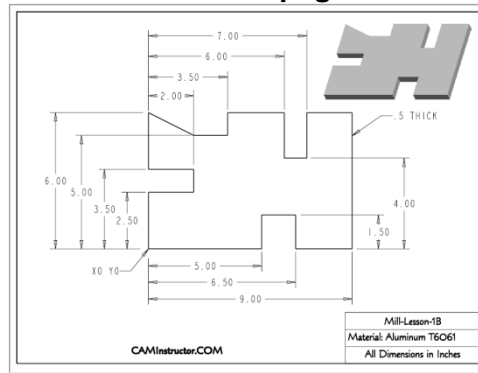

Lesson 2 27



Exercise 2a page 52

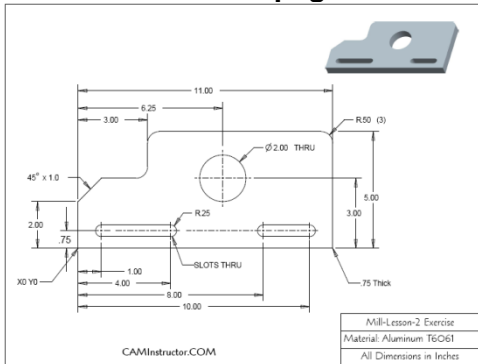

Exercise 2b page 53

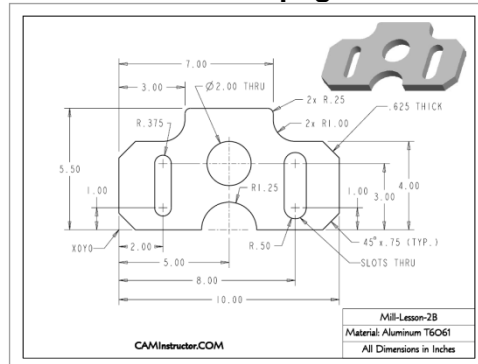

Mill 2D & 3D

Lesson 355

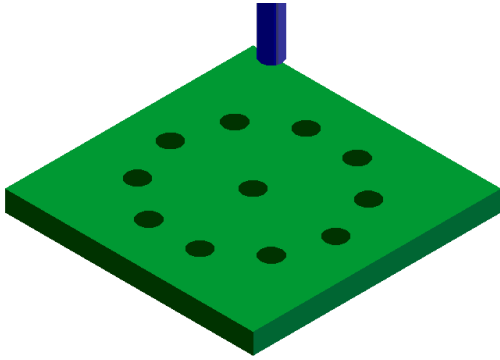

Exercise 3a page 96

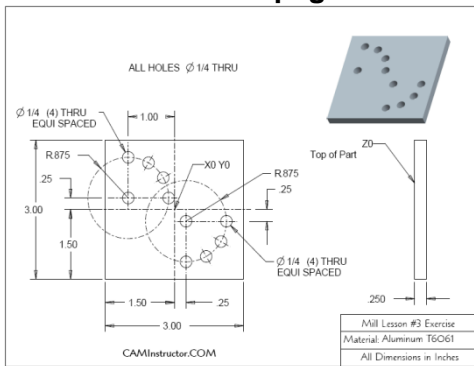

Exercise 3b page 97

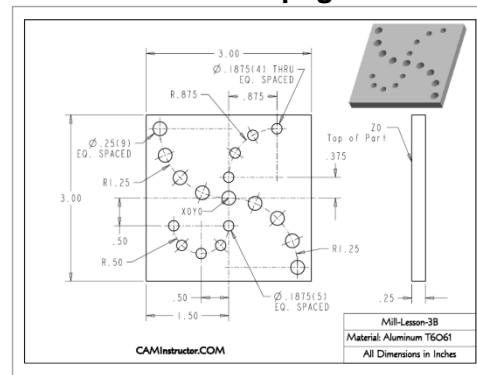

Lesson 499

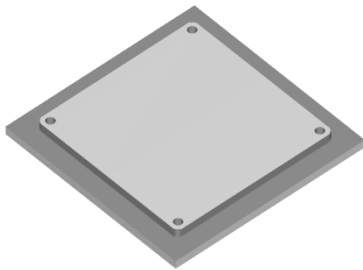

Exercise 4a page 135

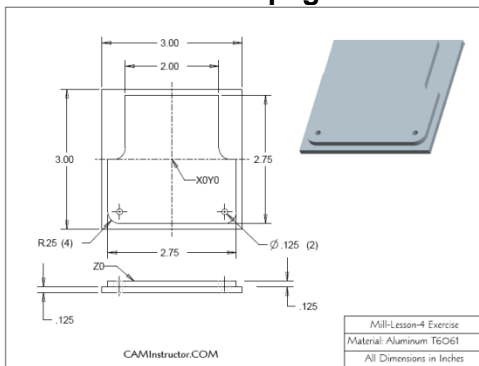

Exercise 4b page 136

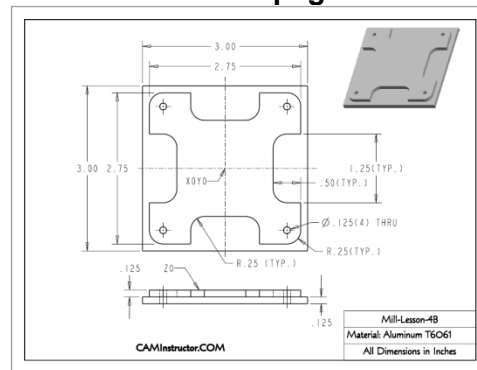

Lesson 5 137

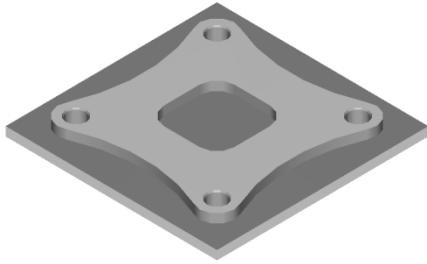

Exercise 5a page 198

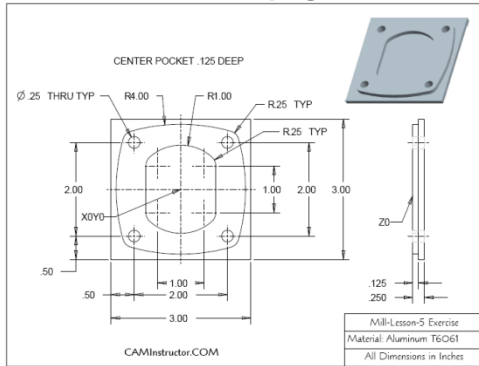

Exercise 5b page 199

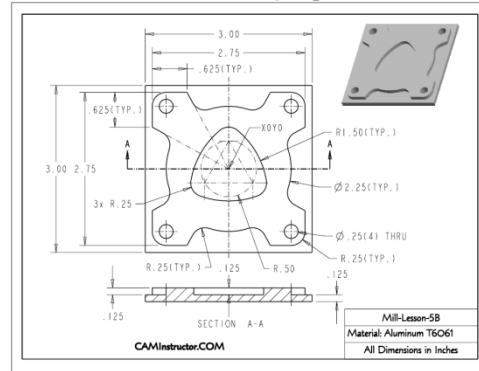

Lesson 6 201

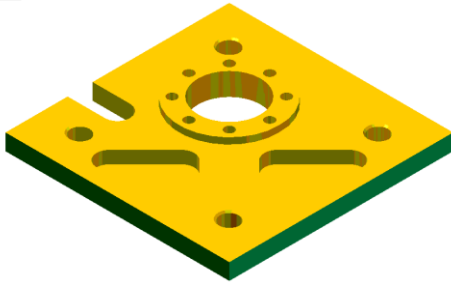

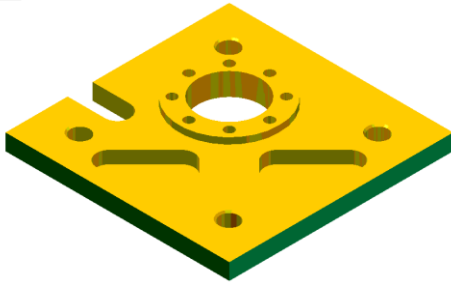

Exercise 7a page 308

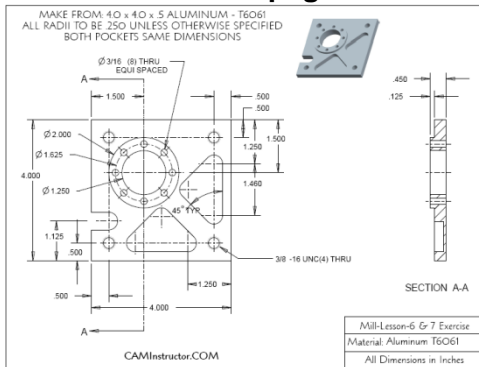

Exercise 7b page 309

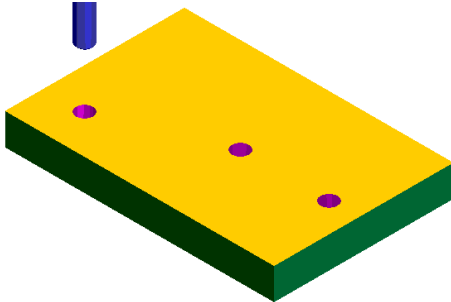
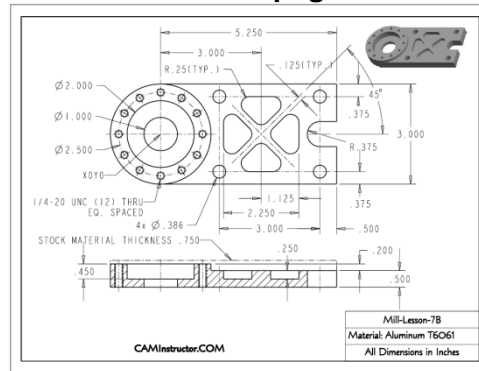

Part 1

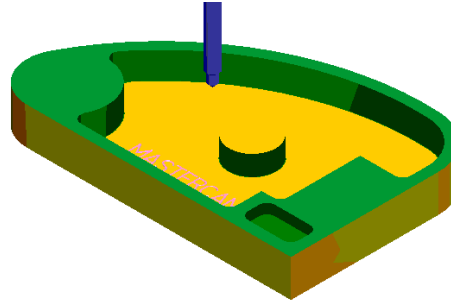

Part 2

Exercise 8a page 392

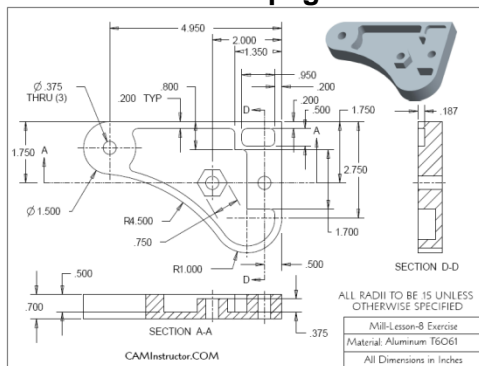

Exercise 8b page 393

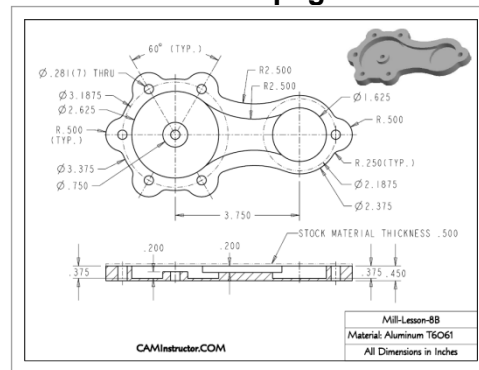

Feature Based Machining Lesson 1395

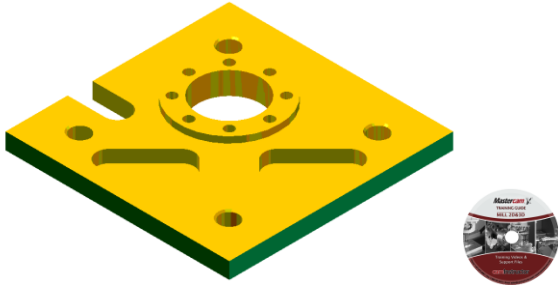

Feature Based Machining Lesson 2397

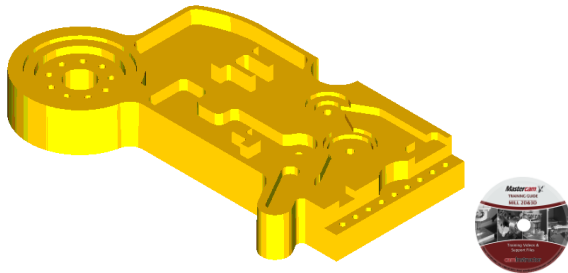

WCS-Part-1399

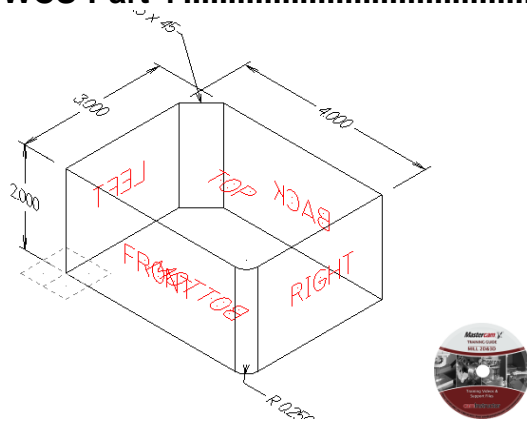

WCS-Part-2401

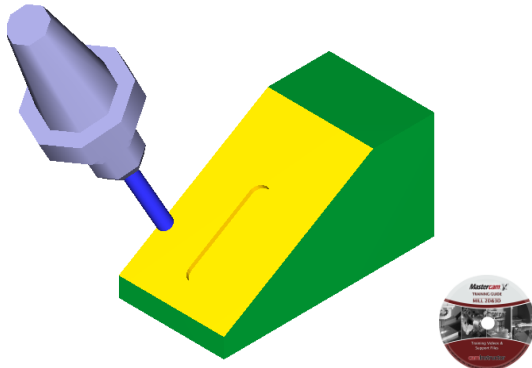

Mill 2D & 3D

WCS-Part-3403

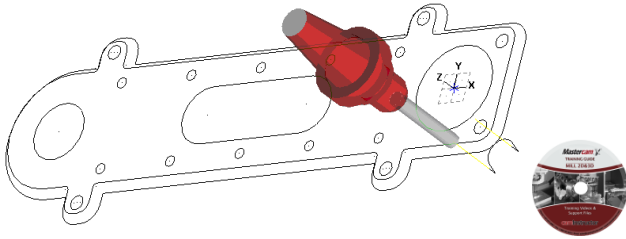

WCS-Part-4405

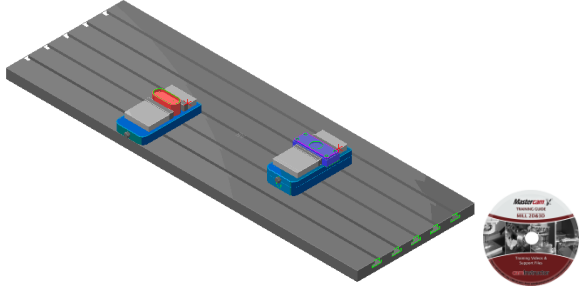

Advanced Exercises407



Also located on the CD

Advanced Exercise 1 407

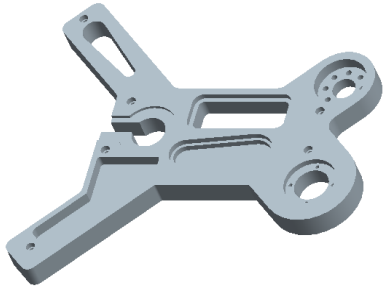

Advanced Exercise 2 411

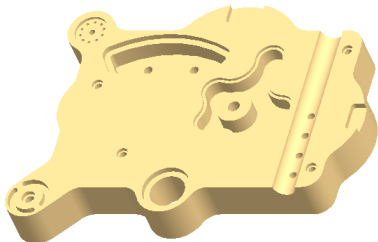

Advanced Exercise 3 415

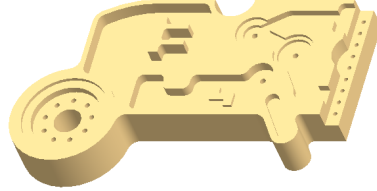

Contents at a Glance Mill 3D

Surface Toolpath Overview.....421

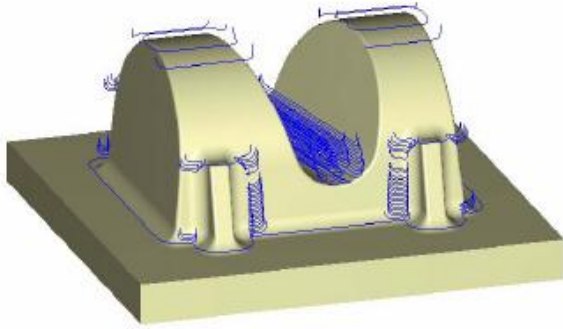

Lesson 9431

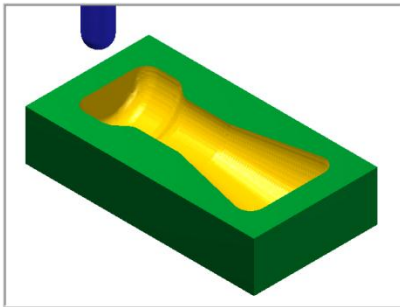

Exercise 9A page 461

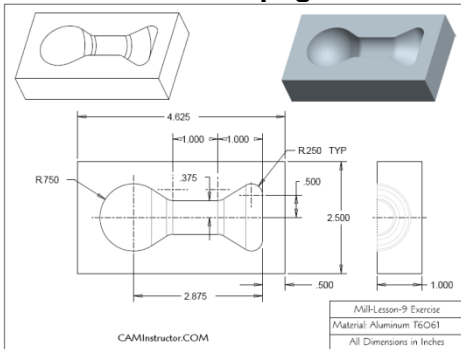

Exercise 9B page 462

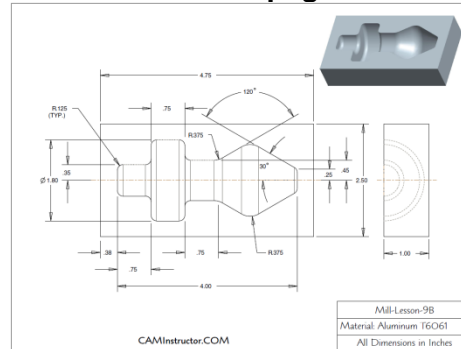

Lesson 10463

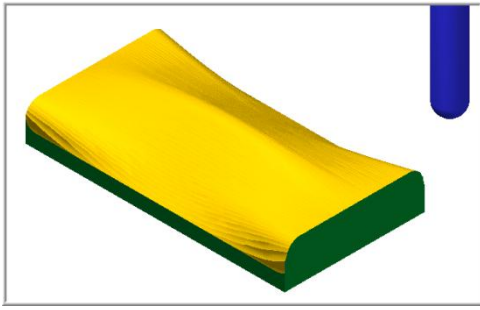

Exercise 10A page 489

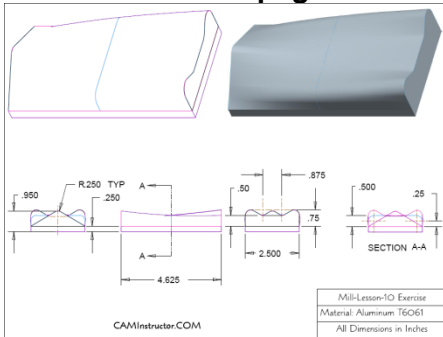

Exercise 10B page 490

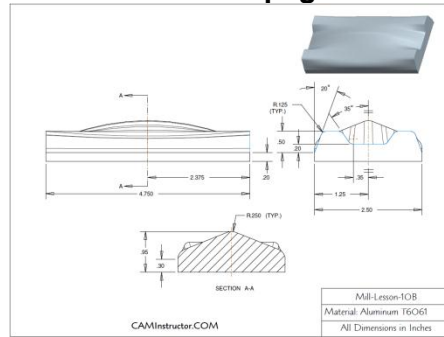

Lesson 11491

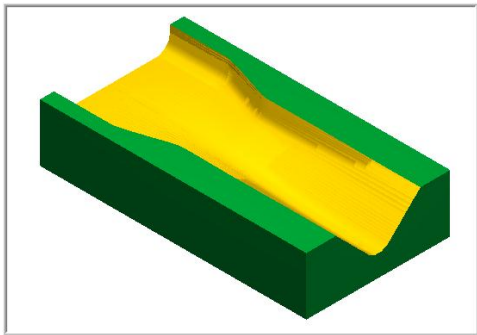

Exercise 11A page 522

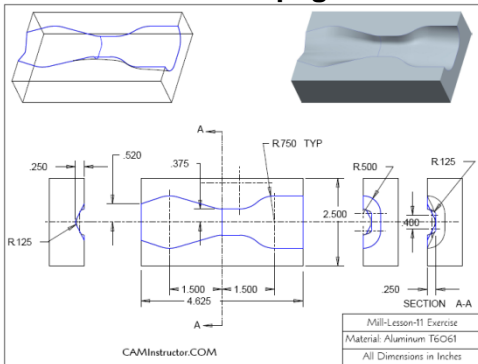

Exercise 11B page 523

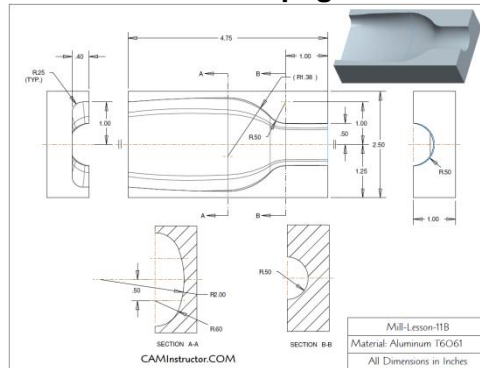

Mill 2D & 3D

Lesson 12525

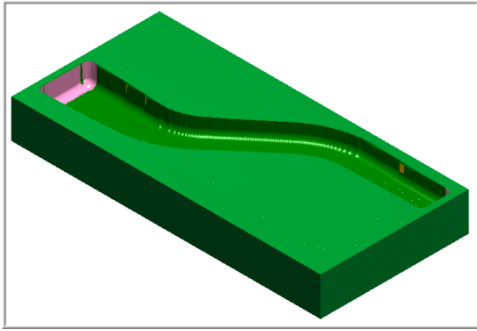

Exercise 12A page 576

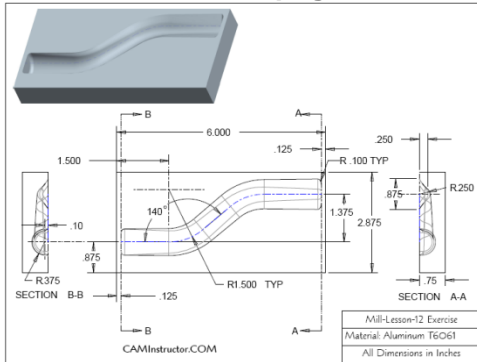

Exercise 12B page 577

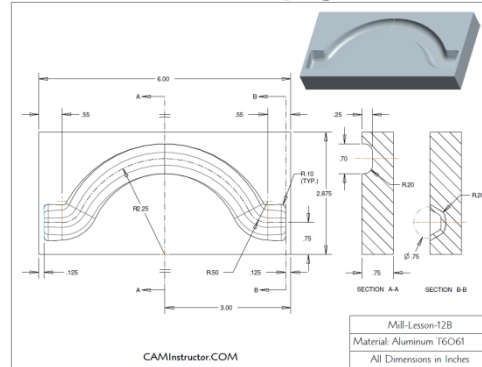

Lesson 13579

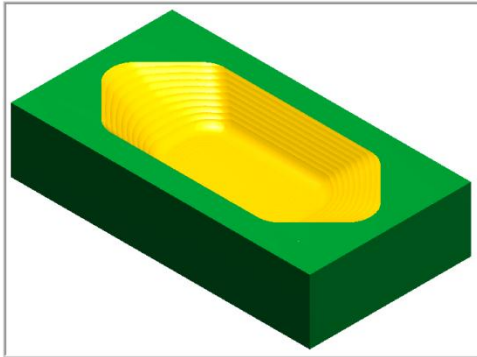

Exercise 13A page 612

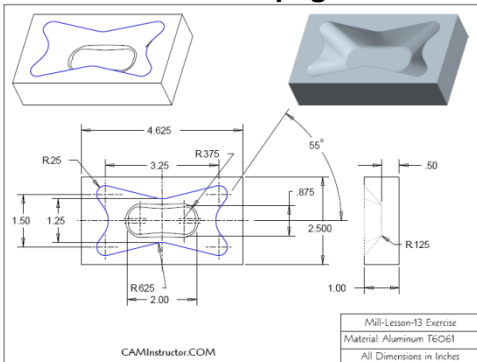

Exercise 13B page 613

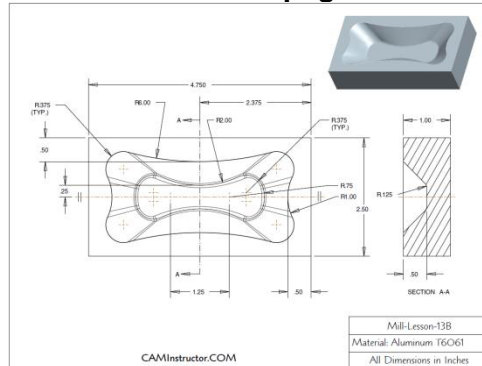

Lesson 14 615

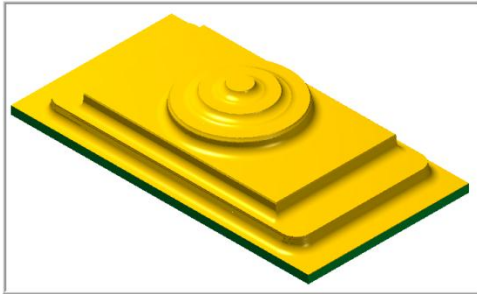

Exercise 14A page 661

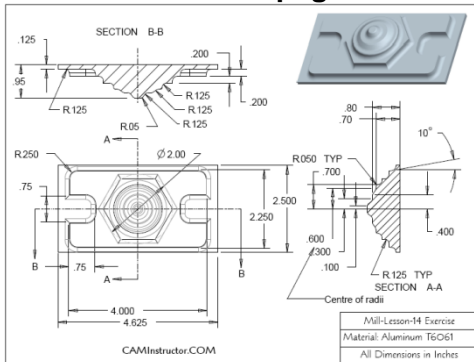

Exercise 14B page 662

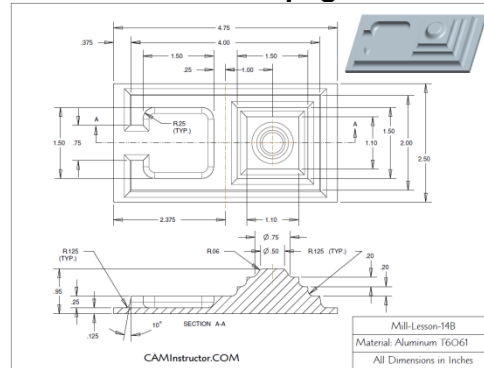

Lesson 15 663

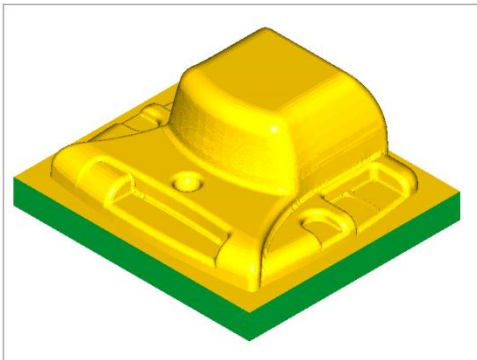

Exercise 15A on DVD

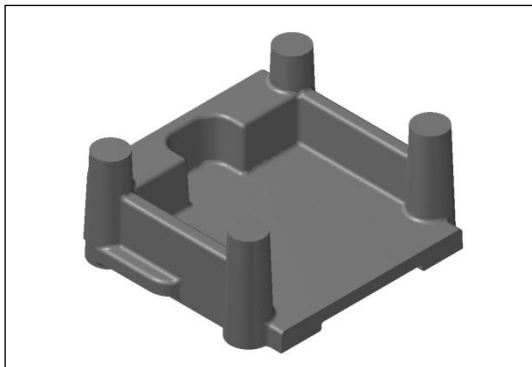

Exercise 15B on DVD

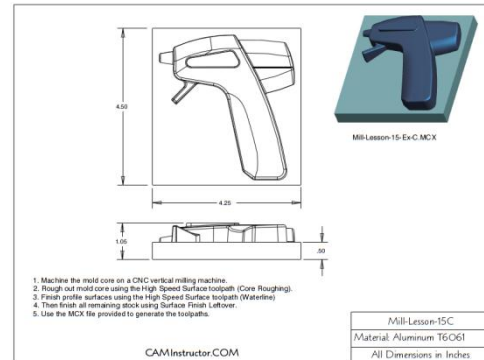

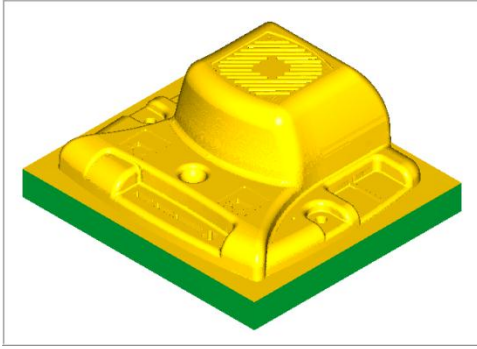

Exercise 16A on DVD

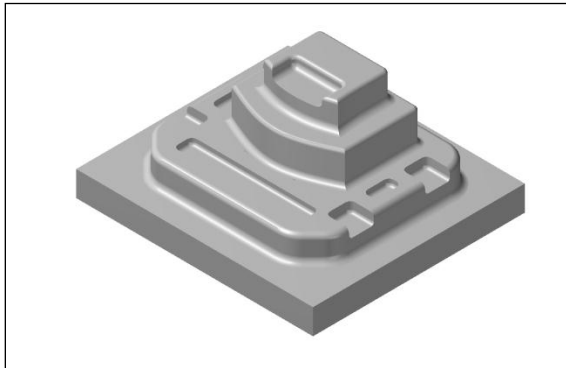

Exercise 16B on DVD

1. Machine the mold core on a CNC vertical milling machine.
2. Rough out mold core using the High Speed Surface toolpaths (Core Roughing & Rest Roughing).
3. Finish profile surfaces using the High Speed Surface toolpaths (Horizontal, Waterline, and Leftover).
4. Use the MCX file provided to generate the toolpaths.

Mtl-Lesson-16C
Material: Aluminum T6061
All Dimensions in Inches

CAMInstructor.COM



What's on the DVD?

1. Training Videos

Getting Started - Video

- -an overview of how the CD works

Setting the Mastercam Environment - Video

Tips and Techniques – Videos including:

- Getting Help – 7 Minutes
- Mastercam Interface – 19 Minutes
- Coordinate System – 10 Minutes
- Creating Lines – 12 Minutes
- Creating Arcs and Circles – 12 Minutes
- Trim and Extend – 5 Minutes
- Xform – 9 Minutes
- Stock Setup – 8 Minutes
- Backplot and Verify – 5 Minutes
- Multi Passes and Depth of Cuts – 8 Minutes
- WCS – Work Coordinate System
4 PDF lessons and videos
- And more videos on how to use Mastercam....

Lesson 1 through Lesson 16 - Videos

- Demonstrations on how to complete each Lesson in the book

Feature Based Machining - Videos

- FBM-Lesson 1 – PDF file of Instructions and supporting Videos
- FBM-Lesson 2 – PDF file of Instructions and supporting Videos

Drawing-Files

- Advanced exercises in .pdf format that can be printed out and used for extra practice

Mastercam-Files

- Mastercam files required by certain Lessons in the book

2. Mastercam Demo Installation Software

Install it onto your computer so you can practice and work in Mastercam. **Please note;** Mastercam Demo Software is a full working copy of Mastercam, however it will NOT allow you to create NC code.

Installation Instructions for Mastercam X5 HLE/Demo Software

1. Insert the DVD into the DVD ROM of your computer
 2. The Training Videos menu may automatically open, you can close this
 3. Open (double click) the My Computer icon on your desktop
 4. Open (double click) the DVD ROM
 5. Open (double click) the Mastercam X5 Demo Software Installation folder
 6. Double click on Setup.exe
 7. Follow the installation wizard for Mastercam Demo Software Installation
-

