

Contents at a Glance

Lesson 1 1

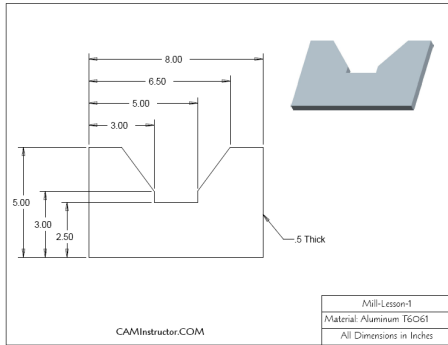

Exercise 1a page 16

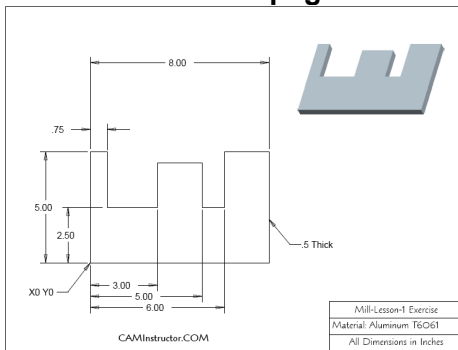

Exercise 1b page 17

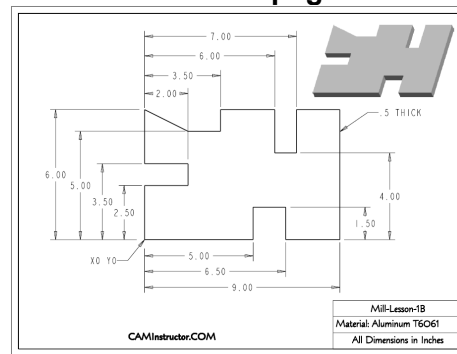

Lesson 2 19

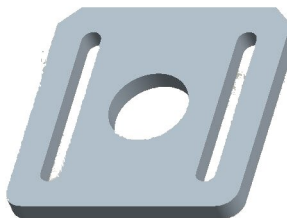
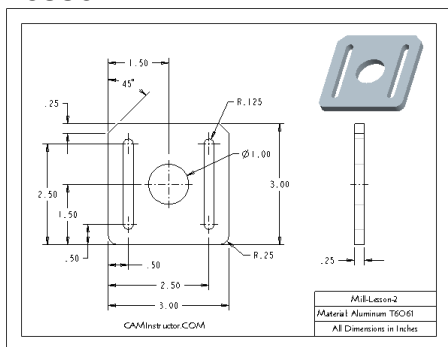

Exercise 2a page 52

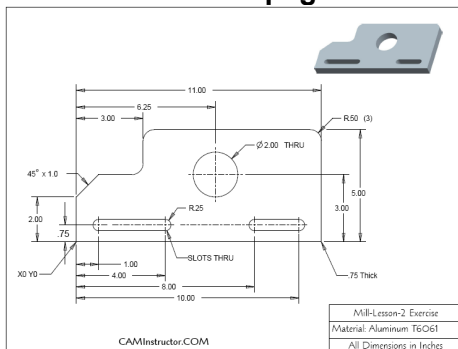

Exercise 2b page 53

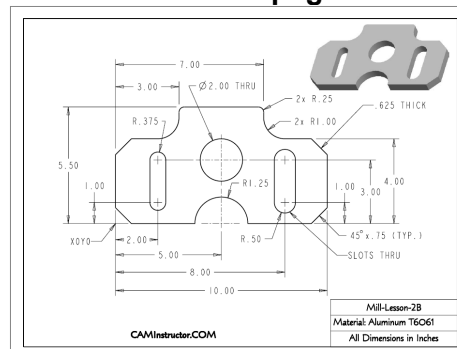

Lesson 3 55

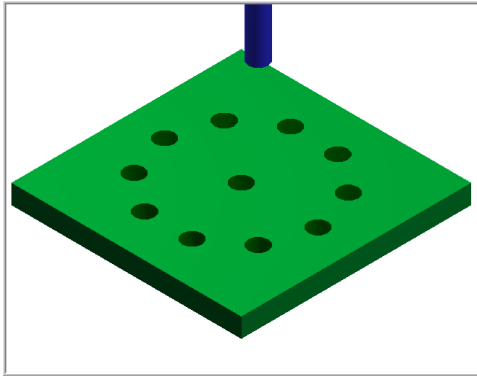

Exercise 3a page 75

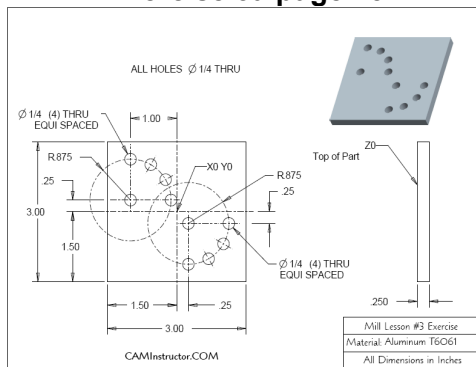

Exercise 3b page 76

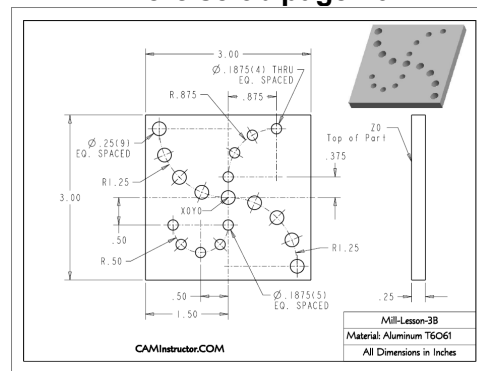

Lesson 4 77

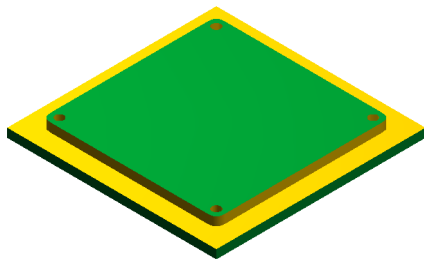

Exercise 4a page 94

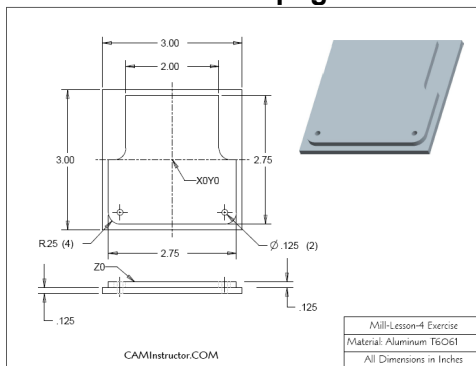

Exercise 4b page 95

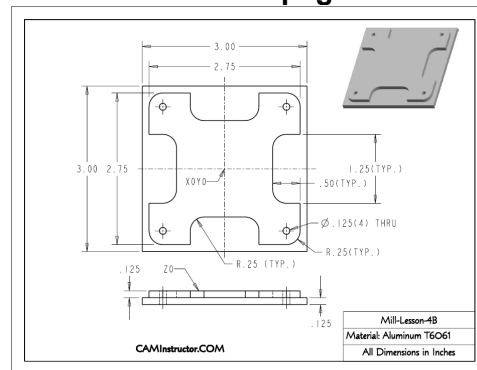

Lesson 5 97



Exercise 5a page 131

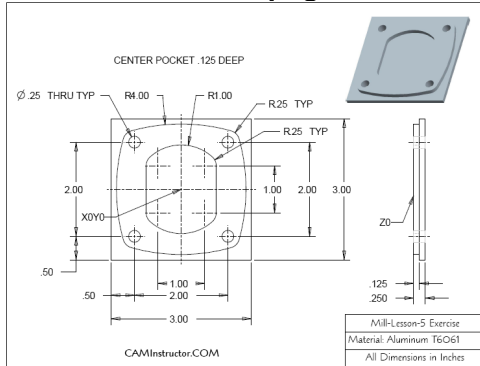

Exercise 5b page 132

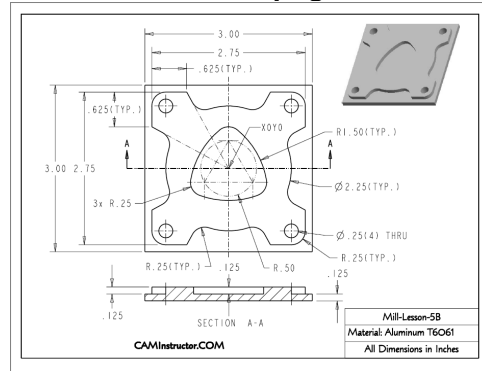

Lesson 6 133

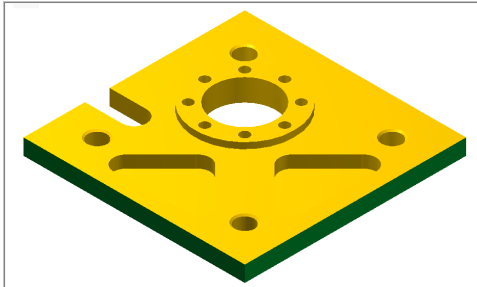

Exercise 6a page 181

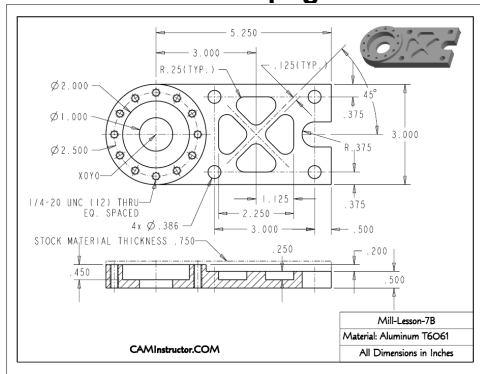

Exercise 6b page 182

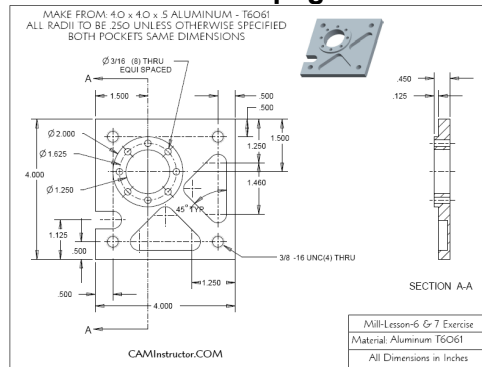

Lesson 13369

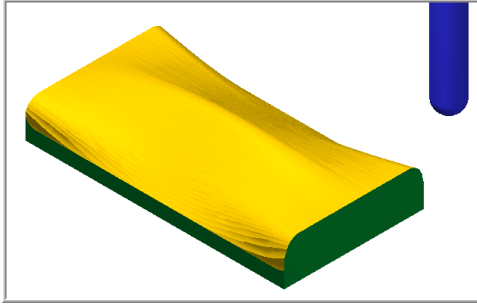

Exercise 13a page 393

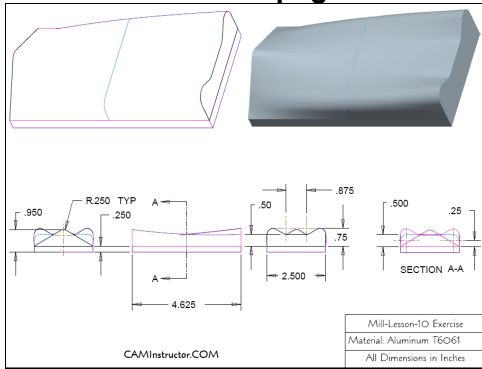

Exercise 13b page 394

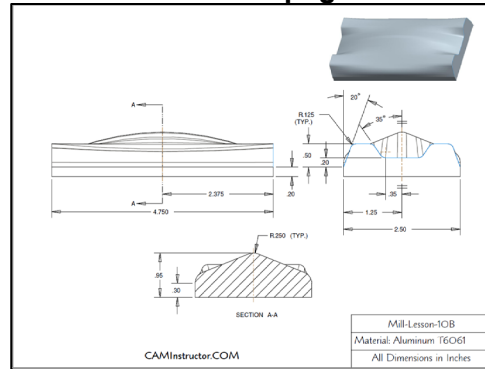



What's on the CD/DVD?

1. Training Videos

Tips and Techniques – Videos including:

- Getting Help – 7 Minutes
- Mastercam Interface – 19 Minutes
- Coordinate System – 10 Minutes
- Creating Lines – 12 Minutes
- Creating Arcs and Circles – 12 Minutes
- Trim and Extend – 5 Minutes
- Xform – 9 Minutes
- Backplot and Verify – 5 Minutes

Lesson 1 through Lesson 13 - Videos

- Demonstrations on how to complete each Lesson in the book

2. Mastercam Demo Installation Software

Install it onto your computer so you can practice and work in Mastercam.

Please note; Mastercam Demo Software is a full working copy of Mastercam, however it will NOT allow you to create NC code.

Installation Instructions for Mastercam Demo Software

1. Insert the CD/DVD into the CD/DVD ROM of your computer
 2. The Training Videos menu may automatically open, you can close this
 3. Open (double click) the My Computer icon on your desktop
 4. Open (double click) the CD/DVD ROM
 5. Open (double click) the Mastercam X5 Demo Software Installation folder
 6. Double click on Setup.exe
 7. Follow the installation wizard for Mastercam Demo Software Installation
-